



Operator's Manual WALK-BEHIND LAWN MOWER

MODEL NO
SM2110

Look Inside for:

	Page
Specifications	2
Safety Definitions	3
Important Safety Information	4-5
Parts & Features	7
Assembly	8-9
Operation	10-12
Maintenance	13-15
Storage	15
Troubleshooting	16
Technical Service	17
Warranty	17-19
Repair Parts	20-22



IMPORTANT:

This manual provides complete instructions for safely operating and maintaining your mower. Read and save these instructions. Refer to this manual each time before using your mower.

Record the following for future reference:

Model No: _____

Mfg. Date Code: _____

Date of Purchase: *Attach a copy of your sales receipt.*

Consumer Toll Free Number: 1-800-737-2112

Refer to the website for electronic manual and parts book.
www.southlandpowerequipment.com



If you have a question or problem...

CALL TOLL FREE: 1-800-737-2112

KEEP THIS MANUAL FOR FUTURE REFERENCE

Specifications

MODEL	SM2110
Cutting Width	21 in (533 mm)
Cutting Depths 3-position height adjust	1" to 3-3/4" (25.4-95.3 mm)
Blade Bolt Torque	25-30 ft/lbs
Unit Weight	60 lb (27.2 kg)
Gasoline Type	Regular Unleaded, \geq 87 Octane Fuel containing Ethanol > 10% is not recommended.*
• Refer to Engine Owner's Manual for engine specifications.	

MEETS CPSC SAFETY REQUIREMENTS

This walk-behind mower conforms to the safety standards of the American National Standards Institute and the U.S. Consumer Product Safety Commission.

⚠ WARNING CALIFORNIA PROPOSITION 65 WARNING

Engine exhaust, some of its constituents, and certain vehicle components contain or emit chemicals known to the State of California to cause cancer and birth defects or other reproductive harm.

⚠ WARNING









The blade turns when the engine is running.

Safety Definitions

• Save all instructions

Become familiar with and understand the meaning of the warning symbols found on your mower.

Safety Warning Symbols



	Indicates WARNING, DANGER, or CAUTION. Use common sense. Watch what you are doing.		Do not mow when children or others are around.
	Read all instructions carefully.		This mower can throw small objects at high speed causing personal injury or property damage. Remove objects that could be thrown by the blade.
	Keep hands and feet away from rotating parts.		Wear eye protection that meets or exceeds the requirements of ANSI Z87.1.
	Do not mow slopes greater than 15°. Mow across slopes, never up and down.		Extremely hot surface. The muffler and engine become hot and can burn you. Do not touch.
	The mower is capable of amputating hands and feet. To avoid risk or serious injury, do not put hands or feet near or under the mower. Keep clear of the discharge opening at all times.		

Control and Operating Symbols

	Push primer 3 times before starting a cold engine. IMPORTANT: Do not prime to restart a warm engine.		Oil Fill Location Do Not Overfill
---	---	---	---

Safety Alert Symbols

The symbols below identify important safety information in this manual. Become familiar with these symbols and the warnings associated with these symbols.

	Indicates an imminently hazardous situation which, if not avoided, will result in death or serious injury.
	Indicates a potentially hazardous situation which, if not avoided, could result in death or serious injury.
	Indicates a potentially hazardous situation which, if not avoided, may result in minor/moderate injury, or equipment/property damage.

Important Safety Information

Important Safety Information

• Save all instructions

⚠ DANGER

Carbon Monoxide. Using an engine indoors can kill you in minutes. Engine exhaust contains high levels of carbon monoxide (CO), a poisonous gas you cannot see or smell. You may be breathing CO even if you do not smell engine exhaust.

⚠ DANGER

The mower is capable of amputating hands and feet and throwing objects. Read and follow all warnings and safety instructions on the mower and in this manual. Failure to do so can result in serious injury or death to you or bystanders.

⚠ WARNING

In order to prevent accidental starting when setting up, transporting, adjusting or making repairs, always disconnect spark plug wire and place wire where it cannot come in contact with plug.

⚠ CAUTION

Muffler and other engine parts become extremely hot during operation and remain hot after engine has stopped. To avoid severe burns on contact, stay away from these areas.

I. GENERAL OPERATION

- Read, understand, and follow all instructions on the machine and in the manual(s) before starting. Be thoroughly familiar with the controls and the proper use of the machine before starting.
- Do not put hands or feet near or under rotating parts. Keep clear of the discharge opening at all times.
- Only allow responsible individuals, who are familiar with the instructions, to operate the machine.
- Clear the area of objects such as rocks, toys, wire, bones, sticks, etc., which could be picked up and thrown by blade.
- Be sure the area is clear of other people, particularly small children, before mowing. Stop machine if anyone enters the area.
- Do not operate the mower when barefoot or wearing open sandals. Always wear substantial foot wear.
- Do not pull mower backwards unless absolutely necessary. Always look down and behind before and while moving backwards.
- Never direct discharged material toward anyone. Avoid discharging material against a wall or obstruction. Material may ricochet back toward the operator.
- Do not operate the mower without proper guards, plates, grass catcher or other safety protective devices in place.
- See manufacturer's instructions for proper operation and installation of accessories. Only use accessories approved by the manufacturer.
- Stop the blade(s) when crossing gravel drives, walks, or roads.
- Stop the engine (motor) whenever you leave the equipment, before cleaning the mower or unclogging the chute.
- Shut the engine (motor) off and wait until the blade comes to complete stop before removing grass catcher or accessories.
- Do not operate the machine while under the influence of alcohol or drugs.

- Never operate machine in wet grass. Always be sure of your footing: keep a firm hold on the handle; walk, never run.
- Disengage the self-propelled mechanism or drive clutch on mowers so equipped before starting the engine.
- If the equipment should start to vibrate abnormally, stop the engine (motor) and check immediately for the cause. Vibration is generally a warning of trouble.
- Always wear safety goggles or safety glasses with side shields when operating mower.

II. SLOPE OPERATION

⚠ WARNING

Slopes are a major factor related to slip and fall accidents, which can result in severe injury. Operation on all slopes requires extra caution. If you feel uneasy on a slope, do not mow it.

- If a slope is greater than 15° do not mow. Use the **Slope Guide** inside this manual to measure slopes before operating this mower on a slope or hilly area.
- Mow across the face of slopes; never up and down. Exercise extreme caution when changing direction on slopes.
- Watch for holes, ruts, bumps, rocks, or other hidden objects. Uneven terrain could cause a slip and fall accident. Tall grass can hide obstacles.
- Do not mow on wet grass or excessively steep slopes. Poor footing could cause a slip and fall accident.
- Do not mow near drop-offs, ditches, or embankments. You could lose your footing or balance.
- If you do lose your balance, release the handle and blade control lever immediately.

Important Safety Information *(Continued)*

• Save all instructions

III. CHILDREN

Tragic accidents can occur if the operator is not alert to the presence of children. Children are often attracted to the machine and the mowing activity. Never assume that children will remain where you last saw them.

- Keep children out of the trimming area and under the watchful care of another responsible adult.
- Be alert and turn machine off if children enter the area.
- Before and while walking backwards, look behind and down for small children.
- Never allow children to operate the machine.
- Use extra care when approaching blind corners, shrubs, trees, or other objects that may obscure vision.

IV. SAFE HANDLING OF GASOLINE

Use extreme care in handling gasoline. Gasoline is extremely flammable and the vapors are explosive.

- Extinguish all cigarettes, cigars, pipes and other sources of ignition.
- Use only an approved container.
- Never remove gas cap or add fuel with the engine running. Allow engine to cool before refueling.
- Never refuel the machine indoors.
- Never store the machine or fuel container where there is an open flame, spark or pilot light such as a water heater or on other appliances.
- Never fill containers inside a vehicle, on a truck or trailer bed with a plastic liner. Always place containers on the ground away from your vehicle before filling.
- Remove gas-powered equipment from the truck or trailer and refuel it on the ground. If this is not possible, then refuel such equipment with a portable container, rather than from a gasoline dispenser nozzle.
- Keep the nozzle in contact with the rim of the fuel tank or container opening at all times until fueling is complete. Do not use a nozzle lock-open device.
- If fuel is spilled on clothing, change clothing immediately.
- Never overfill fuel tank. Replace gas cap and tighten securely.

V. GENERAL SERVICE

- Never run a machine inside a closed area.
- Never make adjustments or repairs with the engine (motor) running. Disconnect the spark plug wire, and keep the wire away from the plug to prevent accidental starting.
- Keep nuts and bolts, especially blade attachment bolts, tight and keep equipment in good condition.
- Never tamper with safety devices. Check their proper operation regularly.
- Keep machine free of grass, leaves, or other debris build-up. Clean oil or fuel spillage. Allow machine to cool before storing.
- Stop and inspect the equipment if you strike an object. Repair, if necessary, before restarting.

- Never attempt to make wheel height adjustments while the engine is running.
- Grass catcher components are subject to wear, damage, and deterioration, which could expose moving parts or allow objects to be thrown. Frequently check components and replace with manufacturer's recommended parts, when necessary.
- Mower blades are sharp and can cut. Wrap the blade(s) or wear gloves, and use extra caution when servicing them.
- Do not change the engine governor setting or over speed the engine.
- Maintain or replace safety and instruction labels, as necessary.

WARNING

This mower is equipped with an internal combustion engine and should not be used on or near any unimproved forest-covered, brush-covered or grass-covered land unless the engine's exhaust system is equipped with a spark arrester meeting applicable local or state laws (if any). If a spark arrester is used, it should be maintained in effective working order by the operator. In the state of California the above is required by law (Section 4442 of the California Public Resources Code). Other states may have similar laws. Federal laws apply on federal lands.

SLOPE GUIDE

SIGHT AND HOLD THIS GUIDE LEVEL WITH A VERTICAL TREE, A CORNER OF A STRUCTURE, A POWER LINE POLE, OR A FENCE.

Use this guide and do not mow on a slope greater than 15 degrees.

A 15-degree slope is a hill that increases in height at approximately 2.5 feet (0.76 meters) in 10 feet (3.05 meters).

WARNING!



Slopes are a major factor related to slip and fall accidents, which can result in severe injury. Operation on all slopes requires extra caution. If you feel uneasy on a slope, do not mow it. Mow across the face of slopes; never up and down. Exercise extreme caution when changing direction on slopes.

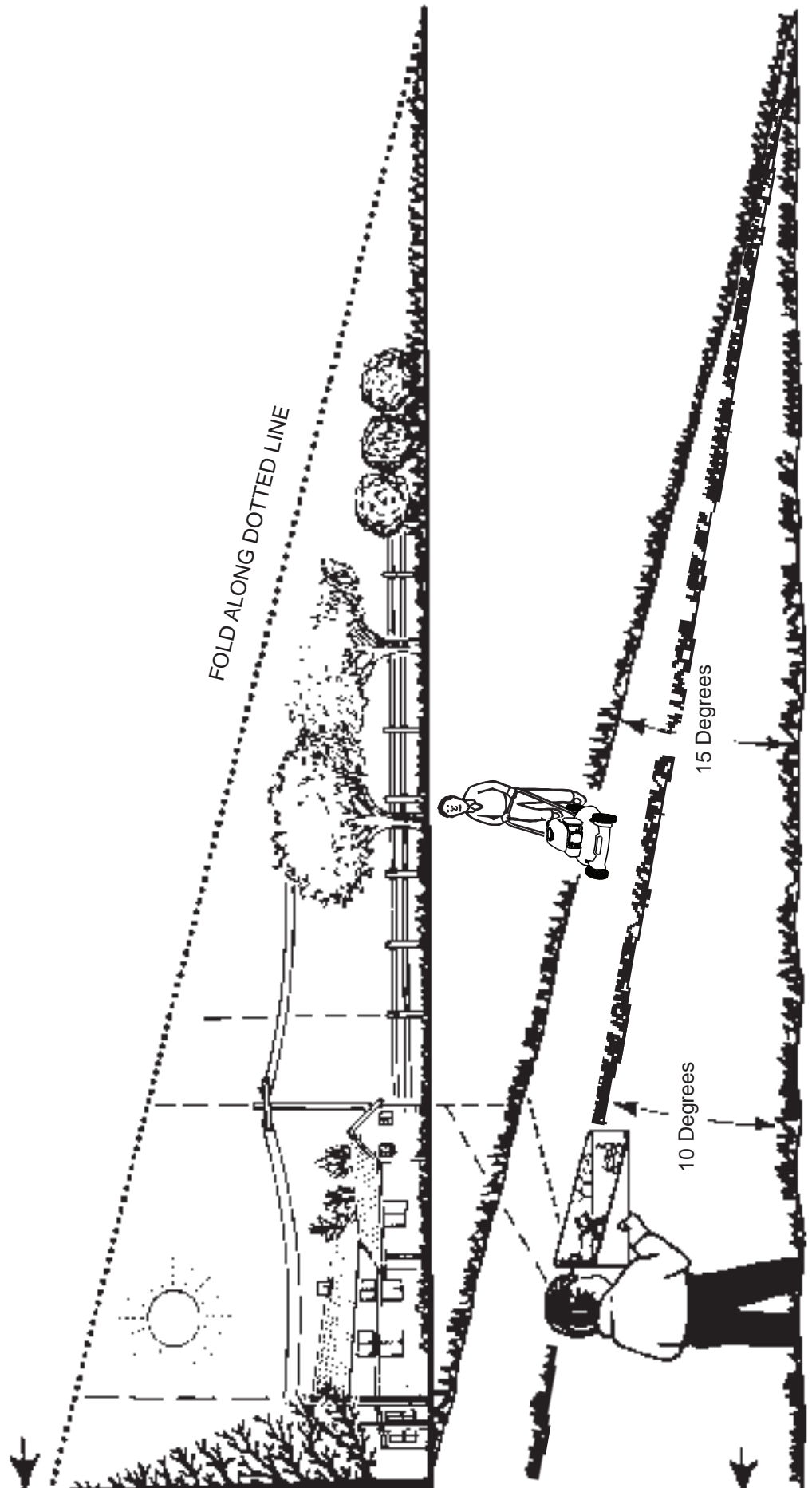

Parts & Features

• Save all instructions

Read, understand, and follow all instructions on the machine and in the manual(s) before starting. To be able to operate your mower safely and get the best performance, become familiar with the controls and the proper use of the machine before starting. Save this manual for future reference.

NOTE: Photographs and line drawings used in this manual are for reference only and may not represent a specific model.

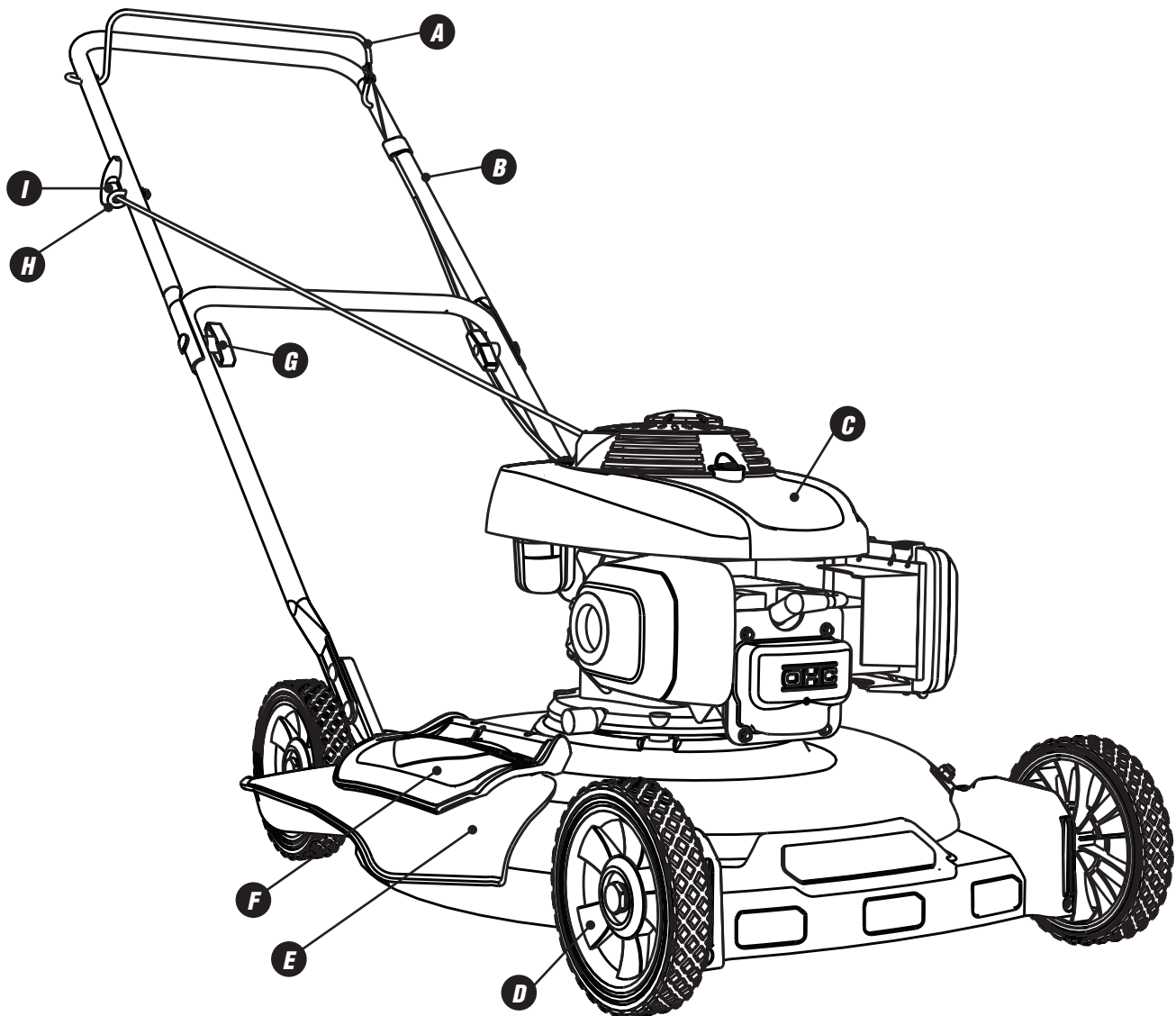

A. Blade Control Lever. Must be held against the handle to start the engine. When released the engine will stop.

B. Handle

C. Engine: Refer to the separate **Engine Owner's manual** for location and operation of engine controls.

D. Wheels: Have a three position height adjustment. Refer to **Adjust Cutting Height** paragraph under **Operation**.

E. Side Discharge Chute: Refer to **Converting Mower From Side Discharge to Mulch Plug** paragraph under **Operation**.

F. Mulching Cover: Stored in position shown. Refer to **Converting Mower From Side Discharge to Mulch Plug** paragraph under **Operation**.

G. Handle Knobs

H. Starter Rope Guide

I. Starter Rope Handle: Used to start engine.

Assembly

• Save all instructions



If you need assistance or find any parts missing, CALL
TOLL FREE: 1-800-737-2112.

NOTE: All references to right or left side of the mower are from the operator's position behind the unit.

IMPORTANT: The assembly instructions were written for persons with some mechanical ability and experience. All steps are not included in these instructions. Persons with some mechanical ability are familiar with tightening fasteners so these steps are not included. Do not attempt to assemble beyond your ability.

This mower was assembled at the factory with the exception of a few parts left unassembled for shipping purposes. To ensure safe and proper operation of this mower, all parts and hardware assembled must be tightened securely. Always use the correct tools to ensure proper tightness. All parts such as nuts, washers, bolts, etc., necessary to complete the assembly have been placed in the parts bag.

⚠ WARNING

Do not operate the mower if it is damaged or not securely and fully assembled.

IMPORTANT: DO NOT ADD ENGINE OIL BEFORE COMPLETING THE ASSEMBLY STEPS BELOW. DURING ASSEMBLY THE ENGINE MAY BE TIPPED FOR EXTENDED TIMES. OIL CAN DRAIN INTO THE UPPER PART OF THE ENGINE CAUSING DIFFICULTY IN STARTING ENGINE.

PARTS INCLUDED WITH THE PACKED MOWER

NOTE: Hardware not shown full size.

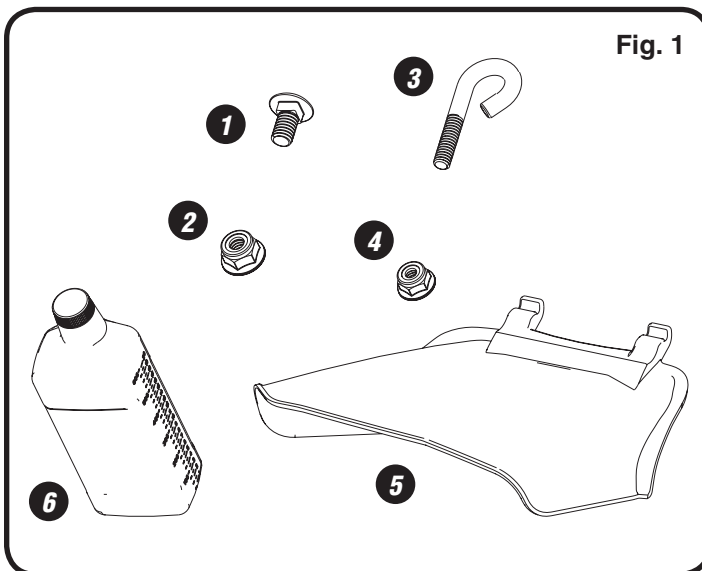

TO REMOVE MOWER FROM CARTON (FIG. 1)

1. Remove loose parts included with mower.
2. Cut down two end corners of carton and lay end panel down flat.
3. Remove all packing materials except padding between upper and lower handle (B) and padding holding blade control lever (A) to upper handle.
4. Roll mower out of carton and check carton thoroughly for additional loose parts.

Item No.	Description	Qty
1 (J)	Screw 5/16-18 round head square neck	2
2 (K)	Locknut 5/16-18 hex nylon insert flange	2
3 (H)	Starter Rope Guide	1
4 (N)	Locknut 1/4-20 hex nylon insert flange	1
6	Oil, 20 fl. oz. (592 ml)	1
not shown	Manual, Owners	1
	Manual, Engine	1
	Wheel Height Instruction Sheet	1

Assembly (Continued)

• Save all instructions



If you need assistance or find any parts missing, CALL TOLL FREE: 1-800-737-2112.

HANDLE ASSEMBLY (FIG. 2-4)

IMPORTANT: Unfold handles being careful not to pinch or damage control cables.

NOTE: Use 1/2 in. wrenches, sockets or adjustable wrenches to complete these steps.

1. Carefully raise handles (B) until lower handle section is in mowing position.

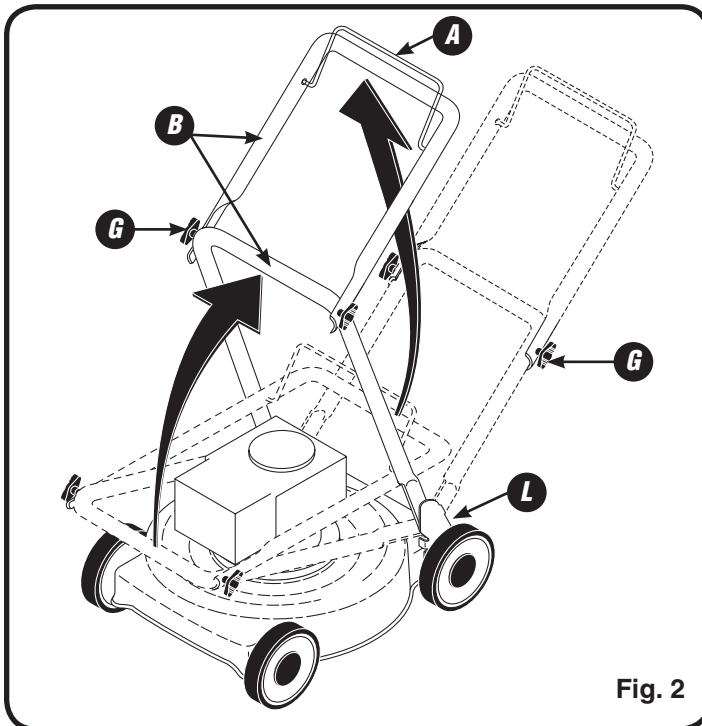

Fig. 2

2. Remove protective padding, raise upper handle section into place on lower handle.

3. Insert screws (J, found in parts bag) into top holes of the handle brackets (L) and secure with locknuts (K, found in parts bag).

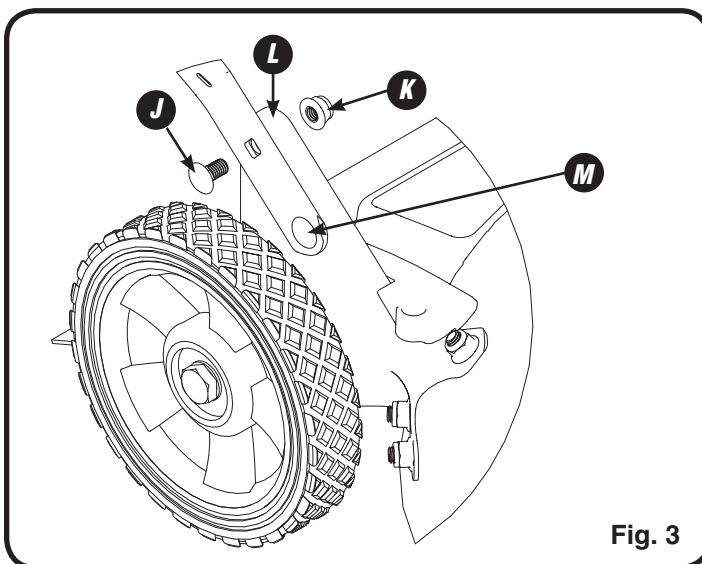

Fig. 3

NOTE: The handle screws (M) in the bottom holes of the handle brackets were left loose for shipping purposes.

4. Tighten all screws to secure handle. Torque to 10 ft/lbs.

5. Tighten both handle knobs (G).

6. Attach starter rope guide (H, found in parts bag) to handle with locknut (N, found in parts bag). DO NOT tighten locknut.

7. Thread starter rope handle (I) through starter rope guide (H) as shown and tighten locknut (N).

8. Remove handle padding holding blade control lever (A) to upper handle.

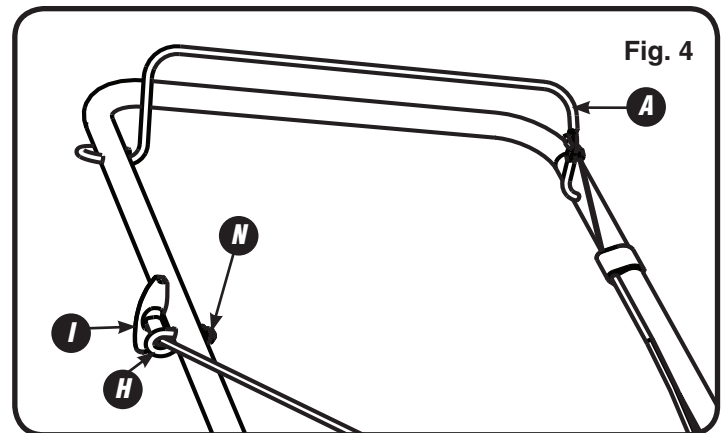

Fig. 4

NOTICE: The engine is shipped without oil. Before starting engine, add oil. Damage to the engine will occur if the engine is run without oil, this damage will not be covered under warranty. Refer to the **Oil** paragraph under **Operation** before starting.

Operation

• Save all instructions

Read, understand, and follow all instructions on the machine and in the manual(s) supplied before starting. Be thoroughly familiar with the controls and the proper use of the machine before starting.



The operation of any mower can result in foreign objects being thrown into the eyes, which can result in severe eye damage. Always wear safety glasses or eye shields while operating your mower or performing any adjustments or repairs. We recommend standard safety glasses or wide vision safety mask be worn over spectacles.

ENGINE SPEED

Engine speed was set at the factory for optimum performance. It is not adjustable.

ENGINE CONTROL

⚠ WARNING

Federal regulations require an engine control to be installed on this mower in order to minimize the risk of blade contact injury. Do not under any circumstances attempt to defeat the function of the blade control lever. The blade turns when the engine is running.

- Your mower is equipped with a blade control lever which requires the operator to be positioned behind the mower handle to start and operate the mower.

BEFORE STARTING ENGINE

ADJUST CUTTING HEIGHT (FIG. 5)

NOTE: Use 9/16 in. wrenches, sockets or adjustable wrenches to complete these steps.

IMPORTANT: Before adjusting the cutting height consider what is best for the lawn being cut. For best results never cut off more than one-third of the total length of the grass.

The cutting height can be adjusted by assembling the wheel (D) into one of the three height adjustment holes (O). The height is adjusted in 0.875" (22 mm) increments.

1. Remove axle bolt (P), wheel (D), washer (Q) and flange nut (R).
2. Reassemble the axle bolt and wheel in the desired cutting height adjustment hole (O). Secure with flange nut.
3. Torque axle bolt to 10 ft/lbs.

NOTE: All four wheels MUST be assembled in the same height position.

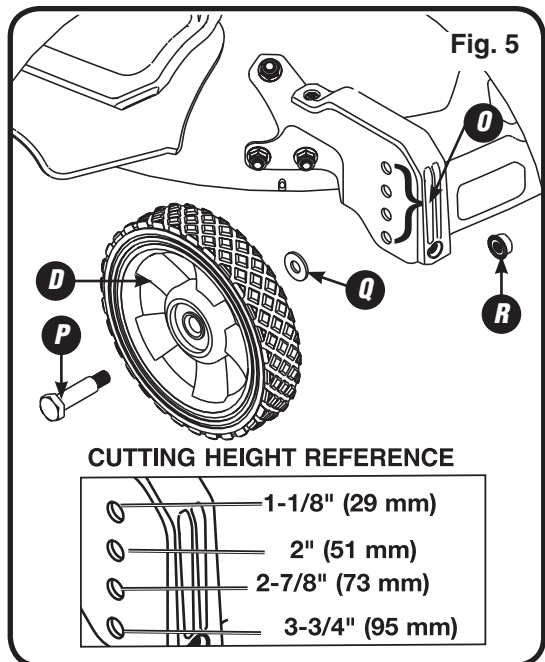

CONVERTING MOWER FROM SIDE DISCHARGE TO MULCH PLUG (FIG. 6)

The mower was shipped as a mulcher.

To convert the mower to side discharge:

Lift the mulching cover (F) and slide the hooks (S) on the side discharge chute (E) under the hinge pin (T) on the mulching cover as shown.

NOTE: DO NOT remove the mulching cover at any time.

To convert the mower from side discharge to mulching:

Lift the mulching cover (F) and slide the side discharge chute (E) from under the hinge pin (T) on the mulching cover. Store the discharge chute in a safe place for future use.

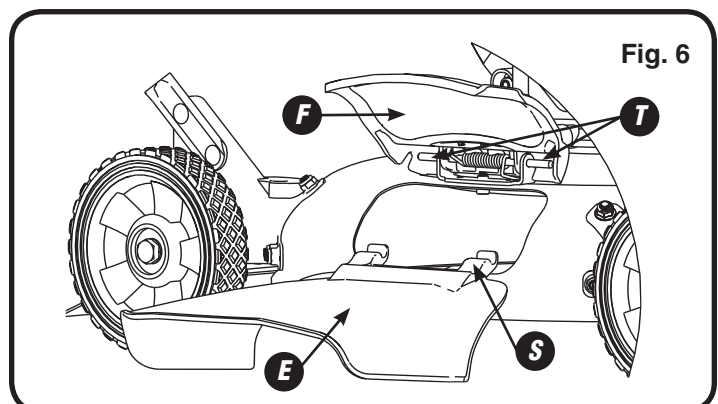

Operation *(Continued)*

• Save all instructions

ADD OIL

Refer to the separate **Engine Owner's manual** for additional engine information.

CAUTION

Check oil level before starting engine. If you start the engine without oil, the engine will be damaged beyond repair and will void your warranty.

CAUTION

Overfilling with oil may cause hard starting, spark plug fouling, and engine smoking.

Your mower's engine is shipped from the factory without engine oil. A container of engine oil is included with your mower. Add Oil, refer to the separate **Engine Owner's manual** for the correct procedure.

NOTE: Initial oil fill may require less than the amount in the container due to residual oil in engine from the manufacturer's quality testing. Slowly pour oil to prevent overfilling.

ADD GASOLINE

Refer to the separate **Engine Owner's manual** for additional engine information.

WARNING

To avoid personal injury or property damage, use extreme care when handling gasoline. Gasoline is extremely flammable and the vapors are explosive. Do not smoke or allow smoking near fuel or the mower. Extinguish all cigarettes, cigars, pipes and other sources of ignition. Never refuel while using a cell phone. Never refuel the mower indoors. Refuel outdoors WHERE THERE ARE NO SPARKS OR FLAMES. Never remove the fuel cap or add fuel with the engine running. Always stop engine and allow to cool before removing fuel cap. Remove fuel cap slowly. Never overfill fuel tank. Avoid spilling fuel or oil. Wipe up all fuel spills.

CAUTION

Fresh fuel prevents buildup of varnish and gum in the carburetor and fuel system. Commonly available fuel additives which reduce varnish and gum in your engine's fuel system can be added according to the manufacturer's instructions. Do not use gasoline which contains ethanol. Do not mix oil with gasoline.

1. In a well ventilated outdoor area add fresh, high quality, unleaded gasoline with a pump octane rating of 87 or higher. Do not overfill. Wipe up spilled fuel before starting the engine. Refer to the separate **Engine Owners Manual** for correct procedure.
2. Move at least 10 ft. (3 m) away from fueling site before starting engine.

TO STOP THE ENGINE (FIG. 7)

WARNING

Wait for the blade to come to a complete stop before attempting to perform any work on the mower.

Release blade control lever (A) to stop the engine and the blade.

Operation (Continued)

• Save all instructions

TO START THE ENGINE (FIG. 7)

NOTE: Due to protective coatings on the engine, a small amount of smoke may be present during the initial use of the product and should be considered normal.

Prior to starting, refer to the separate Engine Owner's manual for proper starting and stopping procedure.

▲ DANGER

Never start or run the mower inside a closed room or building; breathing exhaust fumes can kill. Do not put hands or feet near or under the mower. Keep clear of the discharge opening at all times. Keep children and bystanders away when starting the engine and out of the mowing area.

1. Push the primer (if equipped) slowly three times – waiting about 2 seconds between each push. Refer to the separate Engine Owner's manual for engine control locations.

NOTE: When temperatures are below 55 °F, press primer five times. When restarting a warm engine, do not use the primer.

2. Stand behind the mower handle, grasp the blade control lever (A) and hold it firmly against the upper handle (B).

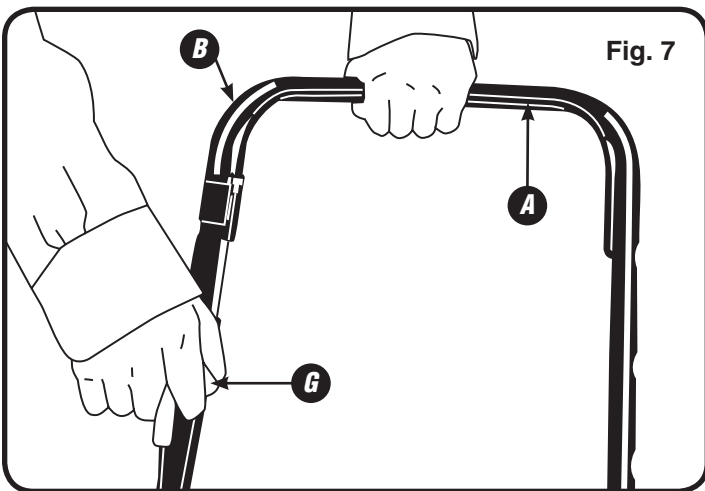

3. Grasp the starter rope handle (G) and pull slowly until resistance is felt, then pull rapidly to start.
4. Slowly return starter rope handle to the starter rope guide and release.

IMPORTANT: To avoid damage to the engine's starter, do not allow the starter rope to snap back against the rope guide.

MOWING TIPS

Thoroughly inspect the area where the mower is to be used and remove all foreign objects such as rocks, wire, toys, etc.

▲ WARNING

This mower can throw small objects at high speed causing personal injury or property damage.

▲ CAUTION

If you strike a foreign object or if the mower starts to vibrate abnormally, stop the engine. Remove spark plug boot from the spark plug, thoroughly inspect the mower for any damage, and repair the damage before restarting and operating the mower. Vibration is generally a warning of trouble.

For best results

- Do not cut wet grass.
- Never cut off more than one-third of the total length of the grass.
- Plan ahead and use a mowing path in a counterclockwise direction that discharges the new grass clippings away from the remaining area to mow.
- Adjust your mowing speed to the condition of the lawn. Do not force mower. It will do the job better, last longer and with less likelihood of a risk of injury at the rate for which it was designed.
- New grass, thick grass or wet grass may require you to use less than the mower's full advertised cutting width.
- When mowing very tall grass, adjust the mower height to its highest setting and make a first cut. Adjust mower to the desired height of the second cut.

Maintenance

• Save all instructions

⚠ WARNING

In order to prevent accidental starting when setting up, transporting, adjusting or making repairs, always disconnect spark plug wire and place wire where it cannot come in contact with plug.

⚠ CAUTION

If the engine has been running, the muffler will be very hot. Be careful not to touch the muffler.

GENERAL

- Always observe all safety warnings when performing any maintenance.
- Maintain the mower with care.
- Inspect the mower periodically. If the mower is not working properly or damaged, have it repaired by a qualified service center.
- Do not change engine governor setting or overspeed the engine.
- Do not remove or modify any parts. Removing or modifying parts could lead to injury, damage the mower and will void the warranty.
- Use only genuine replacement parts and accessories. Unapproved parts or accessories could lead to injury, damage to the unit and void your warranty
- Periodically check all fasteners and ensure they are tight.

LUBRICATION

Keep the unit well lubricated

- Using a light lubricating oil to lubricate pivot points on the blade control lever, wheels and mulcher door hinge.

IMPORTANT: Do not oil or grease plastic wheel bearings. Viscous lubricants will attract dust and dirt that will shorten the life of the self lubricating bearings. If you feel they must be lubricated, use only a dry, powdered graphite type lubricant sparingly.

- Refer to the separate **Engine Owner's manual** for lubrication schedule and instructions for engine lubrication.

CLEANING

IMPORTANT: For best performance, keep mower housing free of grass build-up and trash. Clean the underside of your mower after each use.

⚠ WARNING

In order to prevent accidental starting when setting up, transporting, adjusting or making repairs, always disconnect spark plug wire and place wire where it cannot come in contact with plug.

⚠ CAUTION

Always tip the mower so it is resting on the side of the deck and the air filter side of the engine is facing up. Make sure the mower is resting in a stable position before beginning to clean the deck. Never tip the mower more than 90° in any direction and do not leave the mower tipped for extended periods of time.

Oil can drain into the top part of the engine and cause starting problems.

- Before cleaning the underside of the deck, always drain the fuel tank by running the engine till the tank is empty.
- Clean the underside of your mower by scraping to remove build-up of grass and trash.
- Keep finished surfaces and wheels free of all gasoline, oil, etc.
- We do not recommend using a garden hose to clean mower unless the electrical system, muffler, air filter and carburetor are covered to keep water out. Water in engine can result in shortened engine life.

Maintenance (Continued)

• Save all instructions

ENGINE

A list of key engine maintenance items required for good performance is listed here. Consult the separate **Engine Owners Manual** for the manufacturer's recommendations for any and all engine maintenance.

1. Check engine oil level before each use and maintain oil level as instructed in the separate **Engine Owners Manual**.
2. Service air filter per **Engine Owners Manual** recommendations. Clean every few hours under extremely dusty conditions. Poor engine performance and flooding usually indicates that the air cleaner should be serviced.

⚠ CAUTION

Never run the engine without an air filter installed. Running the engine without the filter can cause excessive engine wear and damage.

3. Clean engine regularly with a cloth or brush. Keep the top of the engine free of debris to permit proper air circulation. Remove all grass, dirt and combustible material from muffler area.

BLADE CARE

For best results, mower blade must be kept sharp. Clean and inspect blade for cracks, nicks or other damage. Replace a blade that is badly worn, bent or damaged with a factory replacement blade.

⚠ CAUTION

Use only a replacement blade shown in the Repair Parts section of this manual. Using a blade not approved by the manufacturer of your mower is hazardous, could damage your mower and void your warranty.

⚠ CAUTION

Use extra care when servicing mower blades. Blades are sharp. To protect your hands, wrap the blade or wear gloves when handling.

TO REMOVE BLADE (FIG. 8)

1. Disconnect spark plug wire from spark plug and place wire where it can not come in contact with plug.
2. Turn mower on its side. Make sure air filter and carburetor are up.
3. Use a wood block between blade and mower housing to prevent blade from turning when removing blade bolt.

NOTE: Protect your hands with gloves and/or wrap blade with heavy cloth.

4. Remove blade bolt (U) by turning counterclockwise.

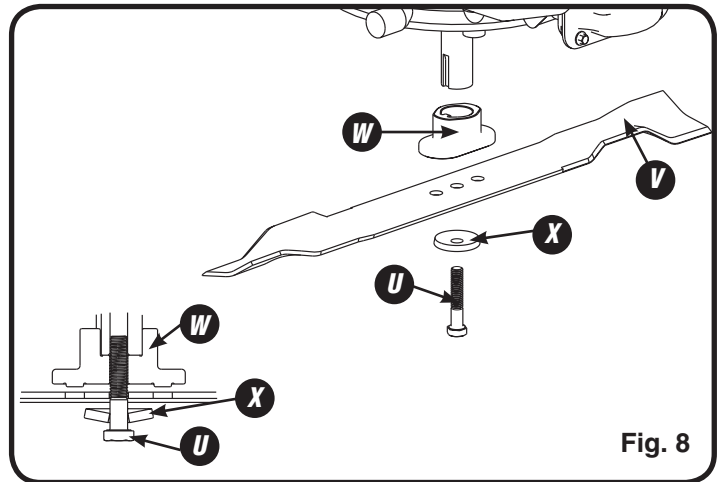

Fig. 8

5. Remove blade (V) and attaching hardware [bolt (U) and disc spring washer (X)].

TO REPLACE BLADE (FIG. 7)

1. Position blade on the blade adapter (W) aligning the two (2) holes in the blade with the raised lugs on the adapter.
2. Be sure the trailing edge of blade (opposite sharp edge) is up toward the engine.
3. Install the blade bolt (U) with the disc spring washer (X) into blade adapter and crankshaft.
4. Use block of wood between blade and mower housing and tighten the blade bolt, turning clockwise. Torque to 25–30 ft/lbs.

IMPORTANT: Periodically check the blade bolt for correct torque.

Maintenance *(Continued)*

• *Save all instructions*

IMPORTANT: Blade bolt is heat treated. If bolt needs replacing, replace only with approved bolt shown in the **Repair Parts** section of this manual.

TO SHARPEN BLADE

NOTE: We do not recommend sharpening the blade- but if you do, be sure the blade is balanced.

CAUTION

An unbalanced blade will cause excessive vibration when rotating at high speeds. It may cause damage to mower and could break causing personal injury.

- The blade can be sharpened with a file or on a grinding wheel. Do not attempt to sharpen while on the mower.
- To check blade balance, drive a nail into a beam or wall. Leave about one inch of the straight nail exposed. Place center hole of blade over the head of the nail. If blade is balanced, it should remain in a horizontal position. If either end of the blade moves downward, sharpen the heavy end until the blade is balanced.

Storage

• *Save all instructions*

Immediately prepare your mower for storage at the end of the season or if the unit will not be used for 30 days or more.

NOTE: If the gasoline in your engine deteriorates during storage, you may need to have the carburetor, and other fuel system components, serviced or replaced. Commonly available fuel additives which reduce varnish and gum in your engine's fuel system can be added according to the manufacturer's instructions. See **Engine Owner's Manual** for more information.

ENGINE

Consult the separate **Engine Owners Manual** for manufacturer's recommendations for storage.

MOWER

When mower is to be stored for a period of time, clean it thoroughly, remove all dirt, grease, leaves, etc. Store in a clean, dry area.

1. Clean entire mower See **Cleaning** in the **Maintenance** section of this manual.
2. Follow **Lubrication** instructions in the **Maintenance** section of this manual.
3. Be sure that all nuts, bolts, screws, and pins are securely fastened. Inspect moving parts for damage, breakage and wear. Replace if necessary.
4. Touch up all rusted or chipped paint surfaces; sand lightly before painting.
5. Coat the cutting blade with a chassis grease to prevent rusting.

Troubleshooting

PROBLEM	POSSIBLE CAUSE(S)	SOLUTION(S)
Engine will not start (see the separate Engine Owner's Manual for further engine troubleshooting)	<ol style="list-style-type: none"> 1. Fuel tank is empty 2. Blade control lever is not depressed 3. Engine not primed 4. Spark plug wire disconnected 5. Fouled spark plug 6. Clogged air filter 7. Engine is flooded 8. Clogged fuel filter 9. Blocked fuel line 10. Stale or contaminated fuel 11. Other 	<ol style="list-style-type: none"> 1. Add fresh fuel. 2. Grasp and hold blade control lever firmly against handle while pulling starter rope handle. 3. Prime engine, see Engine Owner's Manual. 4. Attach spark plug wire to spark plug. 5. Service spark plug, see Engine Owner's Manual. 6. Service air filter, see Engine Owner's Manual. 7. Wait a few minutes and restart engine without priming. 8. Remove fuel filter. Inspect. Replace if necessary. See Engine Owner's Manual. 9. Clear or replace fuel line. See Engine Owner's Manual. 10. Drain fuel tank. Clean fuel tank. Fill with fresh fuel. See Engine Owner's Manual. 11. Take unit to an authorized service center.
Engine runs rough	<ol style="list-style-type: none"> 1. Loose spark plug wire 2. Fouled spark plug 3. Incorrect spark plug gap 4. Clogged air filter 5. Clogged vent in fuel cap 6. Clogged fuel filter 7. Partially blocked fuel line 8. Stale or contaminated fuel 9. Other 	<ol style="list-style-type: none"> 1. Securely attach spark plug wire to spark plug 2. Service spark plug. See Engine Owner's Manual. 3. Service spark plug. See Engine Owner's Manual. 4. Service air filter. See Engine Owner's Manual. 5. Clear vent in fuel cap. 6. Remove fuel filter. Inspect. Replace if necessary. See Engine Owner's Manual. 7. Clear or replace fuel line. See Engine Owner's Manual. 8. Drain fuel tank. Clean fuel tank. Fill with fresh fuel. 9. Contact an authorized service center.
Low Engine Power	<ol style="list-style-type: none"> 1. Grass too high, too thick or wet grass 2. Buildup of grass and debris under mower deck 3. Clogged air filter 4. Engine oil level too high 5. Other 	<ol style="list-style-type: none"> 1. Raise cutting height or reduce cutting width, see Mowing Tips in the Operation section. Let grass dry before cutting. 2. Clean debris on the underside of the mower deck. See Cleaning in the Maintenance section. 3. Service air filter, see Engine Owner's Manual. 4. Check engine oil as instructed in the Engine Owner's Manual; drain and adjust oil level as necessary. 5. Contact an authorized service center.
Engine overheats	<ol style="list-style-type: none"> 1. Engine oil level low 2. Clogged air filter 3. Other 	<ol style="list-style-type: none"> 1. Add engine oil as instructed in the Engine Owner's Manual. 2. Service air filter, see Engine Owner's Manual. 3. Contact an authorized service center.
Excessive Vibration	<ol style="list-style-type: none"> 1. Mower blade loose or unbalanced 2. Bent cutting blade 	<ol style="list-style-type: none"> 1. Tighten blade retaining bolt or balance blade as instructed in Blade Care in the Maintenance section. 2. Replace with a new blade. If vibration continues, contact an authorized service center
Rough or uneven cut	<ol style="list-style-type: none"> 1. Wheel heights not correct 2. Dull blade 3. Buildup of grass and debris under mower deck 	<ol style="list-style-type: none"> 1. Adjust wheel heights, see Height Adjustment in the Operation section. 2. Replace or sharpen blade. See Blade Care in the Maintenance section. 3. Clean debris on the underside of the mower deck. See Cleaning in the Maintenance section.

Technical Service

You may have further questions about assembling, operating, or maintaining this Trimmer. If so, you can contact our Technical Service Department at 1-800-737-2112 (English only).
You may also write to:

METL - CORRESPONDENCE ONLY
ATTN: Technical Service – METL
6700 Wildlife Way
Long Grove, IL 60047



If you need assistance or have any questions, CALL
TOLL FREE: 1-800-737-2112.

When contacting the Technical Service Department, have ready:

- Your Name
- Your Address
- Your Phone Number
- Model Number of Product
- Date of Purchase (include copy of receipt for written requests)

Warranty

Southland® MOWER Limited Warranty

Always specify model number when contacting the factory.

We reserve the right to amend these specifications at any time without notice. The only warranty applicable is our standard written warranty. We make no other warranty, expressed or implied. MAT Engine Technologies, LLC warrants this Mower and any parts thereof, to be free from defects in material and workmanship for one year (90 days for commercial use or for reconditioned unit) from the date of first purchase from an authorized dealer, provided that the product has been properly maintained and operated in accordance with all applicable instructions. This warranty is extended only to the original retail purchaser. The bill of sales or proof of purchase must be presented at the time a claim is made under this warranty. This warranty does not cover commercial, industrial, or rental usage, nor does it apply to parts that are not in original condition because of normal wear and tear, or parts that fail or become damaged as a result of misuse, accident, lack of proper maintenance, tampering, or alteration. Travel, handling, transportation, and incidental costs associated with warranty repairs are not reimbursable under this warranty and are the responsibility of the owner. To the full extent allowed by the law of the jurisdiction that governs the sale of the product, this express warranty excludes any and all other expressed warranties and limits the duration of any and all implied warranties, including warranties of merchantability and fitness for a particular purpose to two years from the date of first purchase, and MAT Engine Technologies, LLC's liability is hereby limited to the purchase price of the product and MAT Engine Technologies, LLC shall not be liable for any other damages whatsoever including indirect, incidental, or consequential damages. Some states do not allow limitation of how long an implied warranty lasts or an exclusion or limitation of incidental or consequential damages, so the above limitation of damages may not apply to you. This warranty provides the original purchaser with specific rights.

For information regarding those rights, please consult the applicable state laws.

METL Corporate Office - CORRESPONDENCE ONLY
ATTN: Technical Service – METL
6700 Wildlife Way
Long Grove, IL 60047

Warranty *(Continued)*

Manufacturer's Warranty Coverage

The emissions control system is warranted for two years. If any emissions-related part on your engine is defective, the part will be repaired or replaced by **METL**.

Owner's Warranty Responsibility

As the power equipment engine owner, you are responsible for the performance of the required maintenance listed in your owner's manual. **METL** recommends that you retain all receipts covering maintenance on your power equipment engine, but **METL** can not deny warranty solely for the lack of receipts or for your failure to ensure the performance of all scheduled maintenance.

As the power equipment engine owner, you should however be aware that **METL** may deny your warranty coverage if your power equipment engine or a part has failed due to abuse, neglect, improper maintenance or unapproved modifications.

You are responsible for presenting your power equipment engine to a distribution center or service center authorized by **METL** as soon as the problem exists. The warranty repairs should be completed in a reasonable amount of time, not to exceed 30 days.

If you have any questions regarding your warranty rights and responsibilities, you should contact

MAT Engine Technologies, Inc.
6700 Wildlife Way
Long Grove, IL 60047
Tel: 1-800-737-2112

Owner's Warranty Responsibility

METL warrants that the product engine is free from defects in materials and workmanship which cause such engine to fail to conform with the U.S. EPA or State of California emissions standards for small spark-ignited nonroad (off-road) engines – as applicable to your HCP product. Small spark-ignited off-road engines manufactured after January 1, 1995 and sold in the State of California and U.S. EPA-certified small spark-ignited nonroad engines manufactured in model year 1997 or later and sold in all of the United States are covered by this Emission Control System Warranty for a period of two years from the date of delivery to the original purchaser. This Emission Control System Warranty is transferable to each subsequent purchaser for the duration of the warranty period. Emission Control System Warranty repairs or replacements will be made without charge for diagnosis, parts or labor. A list of warranted parts is provided below. Normal maintenance items, such as spark plugs, air filters and fuel filters that are included on the list of warranted parts are warranted only up to the first scheduled required replacement interval for such item, as set forth in the Operator's Manual. If any emission control system part is repaired or replaced under the Emission Control System Warranty, it shall be warranted for the remainder of the applicable warranty period. **METL** will also repair or replace other engine components damaged by a failure of any part covered by the Emission Control System Warranty during the Emission Control System Warranty Period. Only parts authorized and approved by **METL** may be used in the performance of any Emission Control System Warranty repairs or replacements and will be provided without charge to the owner. Unapproved, add-on, modified, counterfeit and/or "gray market" parts may not be used to modify or repair the **METL** engine. If such a part has been used in the repair or maintenance of your engine, and an **METL Authorized Service Center** determines it is defective or causes a failure of a part covered under the Emission Control System Warranty, your claim for repair of your engine or product may be disallowed. **METL** shall not be held liable hereunder for failures of any warranted parts caused by the use of such an unapproved, add-on, modified, counterfeit and/or "gray market" part.

How to Obtain Warranty Service

You must take your power equipment engine or the product on which it is installed, along with evidence of the date of the sale to the original purchaser, at your expense, to any **METL Authorized Service Center** during its normal business hours. To locate your nearest **METL Authorized Service Center**, call (800) 737-2112. The product owner shall be responsible for any expenses or charges incurred for service calls or transportation of the product or equipment engine to and from the **METL Authorized Service Center**, including any and all damages or losses incurred during such transportation or shipment.

Warranty *(Continued)*

Exclusions

Failures other than those resulting from defects in material or workmanship are not covered by this Emission Control System Warranty. This Emission Control System Warranty does not extend to emission control systems or parts which are affected or damaged by owner abuse, neglect, improper maintenance, misuse, mis-fueling, improper storage, accident and/or collision, the incorporation of, or any use of, any unapproved, add-on, modified, "graymarket" or counterfeit parts, unsuitable attachments, or the unauthorized alteration of any part. This Emission Control System Warranty does not cover the regular replacement of normal maintenance items made in connection with required maintenance services after the item's first scheduled replacement, as set forth in the Operator's Manual (e.g. spark plugs, air filters, fuel filters, etc...).

Limitations of Liability

METL disclaims any responsibility for loss of time or use of the engine, or the equipment in which the engine is installed, transportation, commercial loss, or any other incidental or consequential damage. Any implied warranties are limited to the duration of this written limited warranty. Some states do not allow limitations on how long an implied warranty lasts and/or do not allow the exclusion or limitation of incidental or consequential damages, so the above exclusions and limitations may not apply to you.

This warranty gives you specific legal rights, and you may also have other rights which vary from state to state.

Repair Parts

MODEL NUMBER SM2110

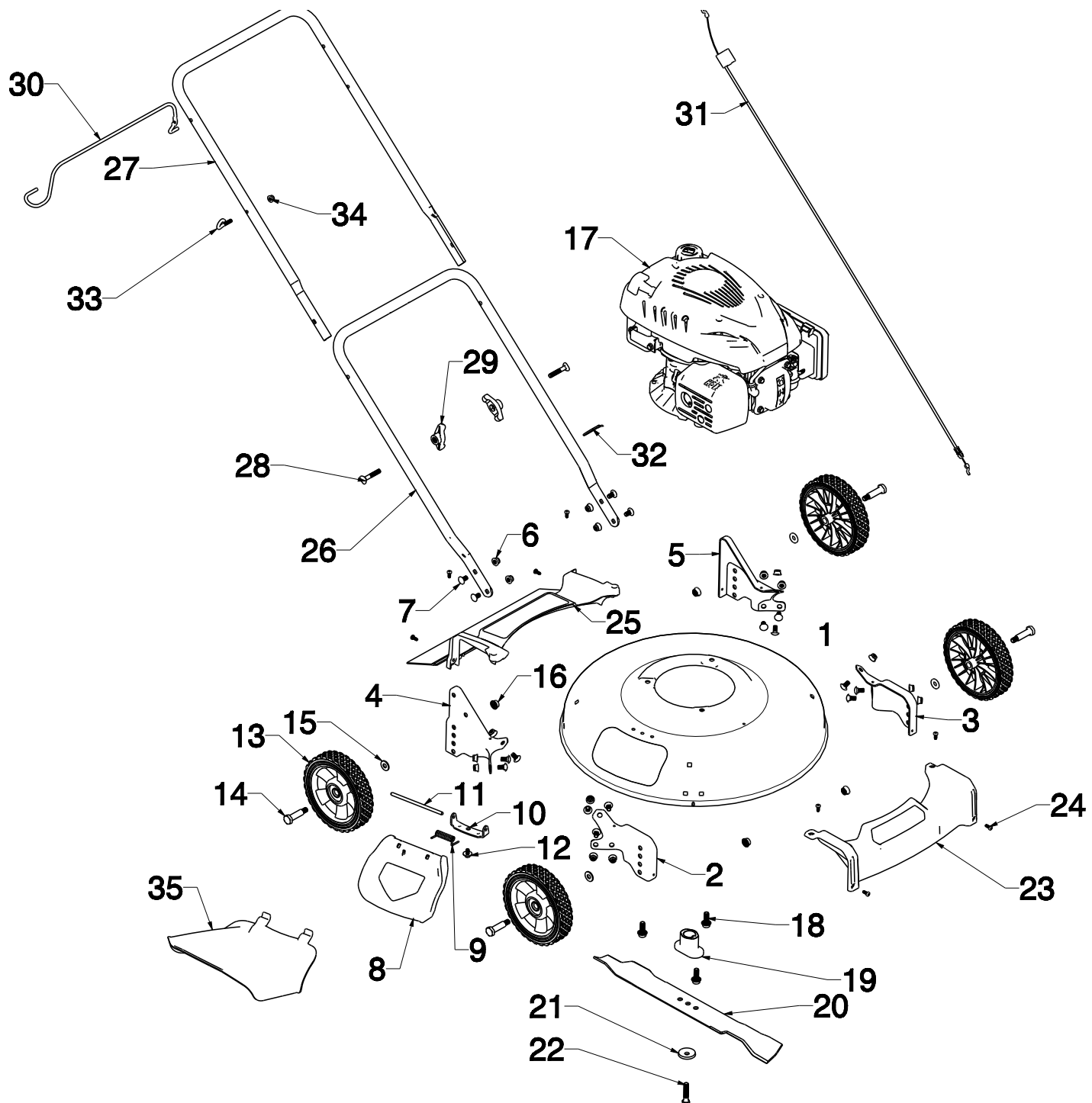

Repair Parts

SM2110 LAWN MOWER REPAIR PARTS

Item	Component No.	Description	Qty	Um
1	A202286	Deck 21" Side Discharge	1	EA
2	A202185	Bracket 4 Hole Rt Front Wheel	1	EA
3	A202184	Bracket 4 Hole Lt Front Wheel	1	EA
4	A202187	Bracket 4 Hole Rt Rear Wheel	1	EA
5	A202186	Bracket 4 Hole Lt Rear Wheel	1	EA
6	A202197	Nut 5/16-18 Nylon Hex Flange	16	EA
7	A202196	Screw 5/16-18 Round Head Square Neck	16	EA
8	A202167	Cover Mulch	1	EA
9	A202170	Spring Torsion	1	EA
10	A202168	Bracket Mulch Cover	1	EA
11	A202169	Pin	1	EA
12	A202171	Assembly 1/4-20 Screw and Washer	1	EA
13	A202178	Wheel 7 x 1.5 Mag Hub/Diamond Tread	4	EA
14	A202198	Screw Hex Flange Hd Shoulder .5 X 1.50	4	EA
15	A202199	Washer 3/8" ID X 7/8" OD X .105"	4	EA
16	A202200	Nut 3/8-16 Serrated Hex Flange	4	EA
17	A202148	Engine RATO RV140 139CC	1	EA
18	A202192	Screw 3/8-16 Hex Head Trilobe	3	EA
19	A202349	Adapter Blade - 25 mm	1	EA
20	A202193	Blade 21" Mulch	1	EA
21	A202194	Washer Belleville 3/8 Conical Spring	1	EA
22	A202335	Screw Hex Head Cap .375-24 UNF X 1.75	1	EA
23	A202173	Cover Front	1	EA
24	A202329	Screw T25 Torx Drive Pan Head 10-24 UNC X .50	8	EA
25	A202322	Assembly Rear Cover/Rear Guard	1	EA
26	A202188	Handle, Lower	1	EA
27	A202189	Handle, Upper	1	EA
28	A202203	Screw, Saddle 5/16-18 X 1/75 Sq Neck	2	EA
29	A202204	Knob 5/16-18	2	EA
30	A202036	Bail, Wireform	1	EA
31	A202164	Cable, Zone Control	1	EA
32	A202245	Tie Wire	1	EA
33	A202201	Wireform Rope Guide	1	EA
34	A202202	Nut 1/4-20 Nylon Hex Flange Lock	1	EA
35	A202166	Side Discharge Chute	1	EA

Repair Parts

Decal Group



Item	Part No.	Description	Qty
1	A202285	Label, Decorative (SOUTHLAND)	1
2	A202250	Label, Decorative (Cyclonic Force)	1
3	A202275	Label, Decorative (Made in USA)	1
4	A202268	Label, Decorative (139CC Magna Force)	1
5	A202325	Label, Warning	1

Repair Parts

SM2110 ENGINE REPAIR PARTS - CYLINDER HEAD

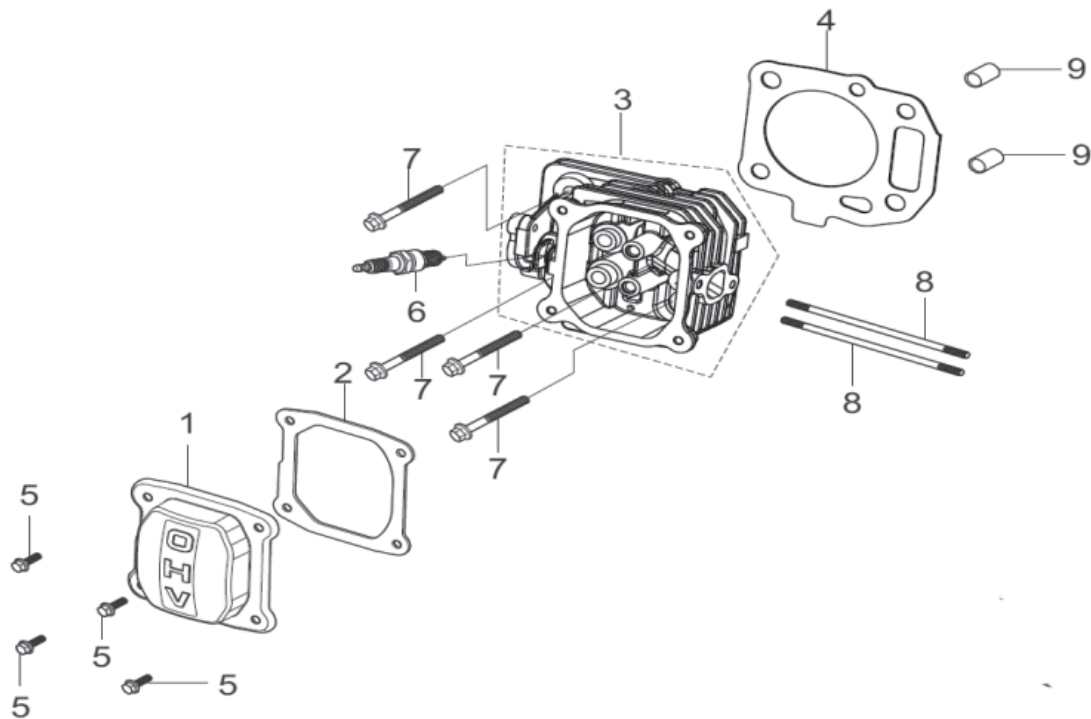

REF. NO.	DESCRIPTION	PART NO.	QTY
1	Cover, Cylinder Head	A201566	1
2	Gasket, Cylinder Head Cover	A201567	1
3	Head, Cylinder	A201568	1
4	Gasket, Cylinder Head	A201569	1
5	Flange Bolt, Cylinder Cover	A201570	4
6	Plug, Spark (Torch F7TC, NGK BPGES, Champion RN9YC4)	A201233	1
7	Flange Bolt, Cylinder Head	A201571	4
8	Bolt, Stud	A201572	2
9	Pin, Dowel	A201573	2

Repair Parts

SM2110 ENGINE REPAIR PARTS - CRANKCASE

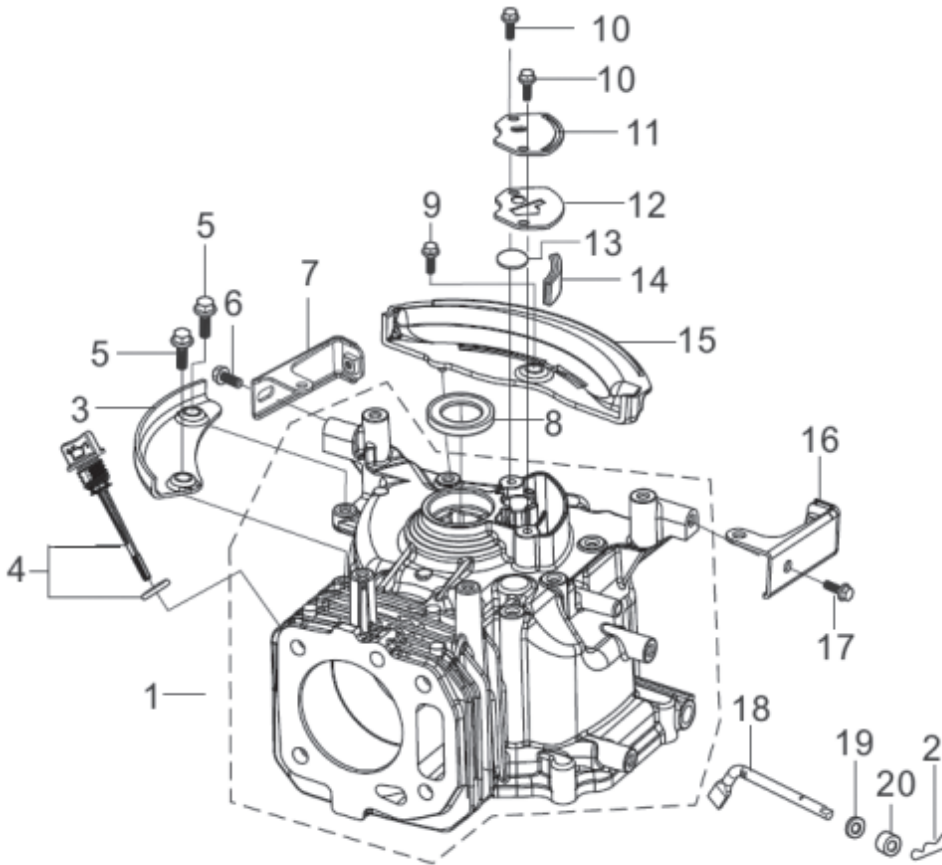

REF. NO.	DESCRIPTION	PART NO.	QTY
1	Sub Assembly, Crankcase	A201574	1
2	Pin, Governor	A201258	1
3	Shield, Crankcase Side	A201576	1
4	Sub Assembly, Dipstick Oil	A201577	2
5	Bolt, Side Shield Flange	A201578	1
6	Bolt, Right Tank Bracket	A201579	1
7	Bracket, Fuel Tank Right	A201580	1
8	Seal, Oil	A201581	1
9	Bolt, Rear Shield	A201582	1
10	Bolt, Breather Bracket	A201583	2
11	Plate, Breather Cover	A201584	1
12	Gasket, Breather Cover	A201585	1
13	Retainer, Breather	A201586	1
14	Element, Breather	A201587	1
15	Shield, Crankcase Rear	A201588	1
16	Bracket, Fuel Tank Left	A201589	1
17	Bolt, Left Tank Bracket	A201590	1
18	Arm, Governor	A201591	1
19	Washer, 6x13x1	A201256	1
20	Seal, Oil 6x11x4	A201257	1

Repair Parts

SM2110 ENGINE REPAIR PARTS - CRANKCASE COVER

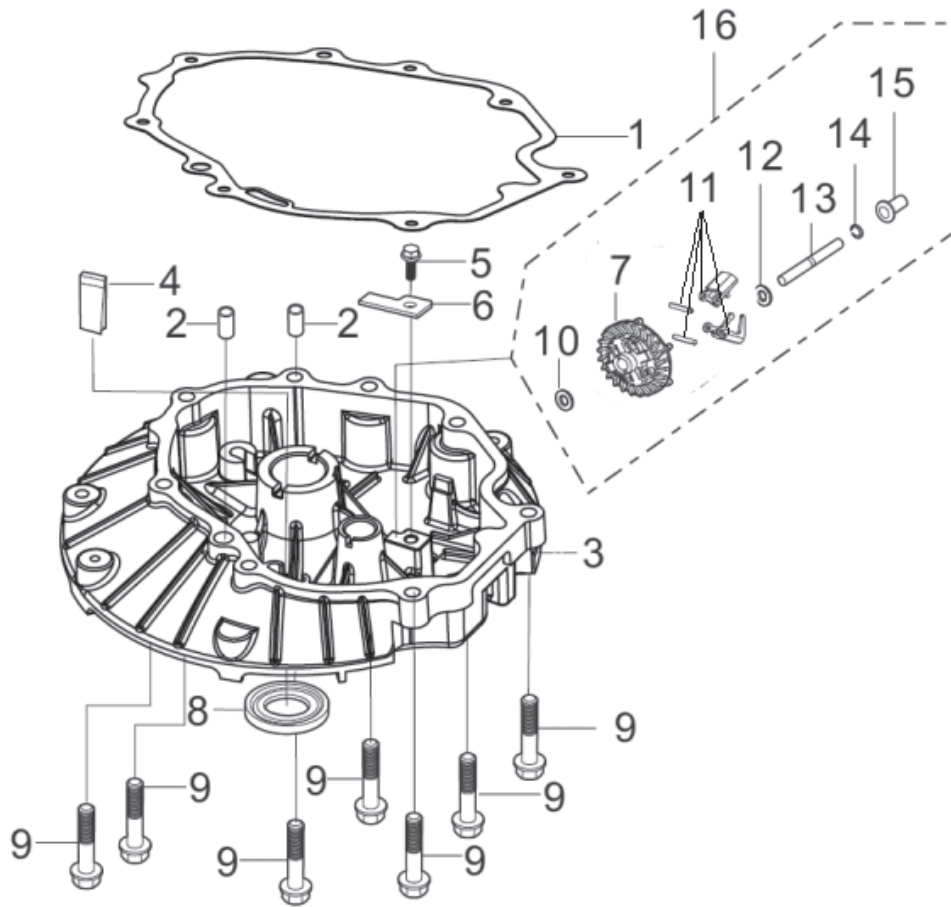

REF. NO.	DESCRIPTION	PART NO.	QTY
1	Gasket, Crankcase	A201592	1
2	Pin, Dowel	A201593	2
3	Cover, Crankcase	A201594	1
4	Rubber Bracket, Oil	A201595	1
5	Bolt, Governor Plate	A201596	1
6	Plate, Governor	A201597	1
7	Gear, Governor Drive	Reference Only	1
8	Seal, Oil	A201599	1
9	Bolt, Flange	A201600	7
10	Washer, Spacer	Reference Only	2
11	ASM, Governor Mechanism	Reference Only	1
12	Washer, Spacer	Reference Only	2
13	Shaft, Governor	Reference Only	1
14	Clip, Retainer	Reference Only	1
15	Sleeve, Governor Actuator	Reference Only	1
16	ASM, Governor	A201607	1

Repair Parts

SM2110 ENGINE REPAIR PARTS - CRANKSHAFT / PISTON

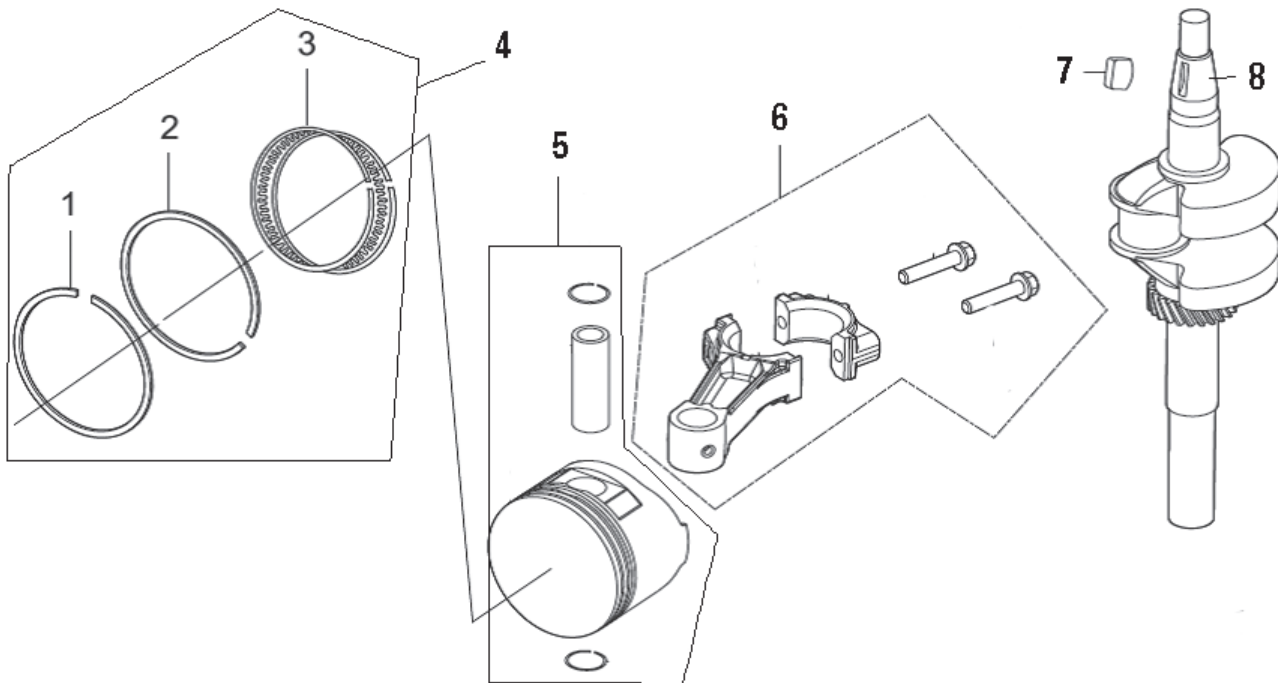

REF. NO.	DESCRIPTION	PART NO.	QTY
1	Ring, Piston - 1	Reference Only	1
2	Ring, Piston - 2	Reference Only	1
3	Ring Set, Oil	Reference Only	1
4	Ring Set, Piston	A201611	1
5	Piston Kit	A202154	1
6	ASM, Connecting Rod	A201615	1
7	Key, Flywheel	A201618	1
8	ASM, Crankshaft	A201619	1

Repair Parts

SM2110 ENGINE REPAIR PARTS - CAMSHAFT

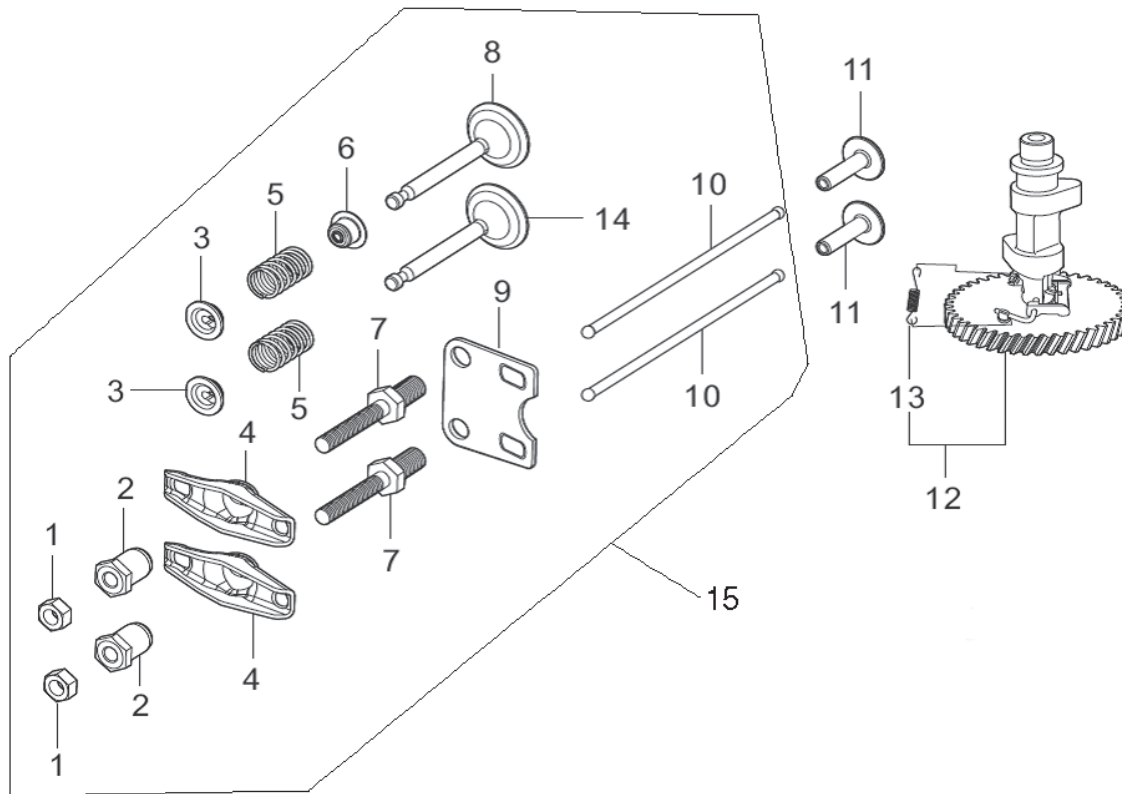

REF. NO.	DESCRIPTION	PART NO.	QTY
1	Nut, Valve Lock	Reference Only	2
2	Nut, Valve Adjusting	Reference Only	2
3	Seat, Valve Spring	Reference Only	2
4	Valve, Rocker	Reference Only	2
5	Spring, Valve	Reference Only	2
6	Retainer, Valve Spring	Reference Only	1
7	Bolt, Valve Adjusting	Reference Only	2
8	Valve, Intake	A201627	1
9	Bracket, Valve	Reference Only	1
10	Rod, Camshaft	Reference Only	2
11	Lifter, Valve	A201630	2
12	ASM, Camshaft	A201631	1
13	Spring, Actuator	A201632	1
14	Valve, Exhaust	A201633	1
15	Kit, Valve	A201634	1

Repair Parts

SM2110 ENGINE REPAIR PARTS - ENGINE SHROUD

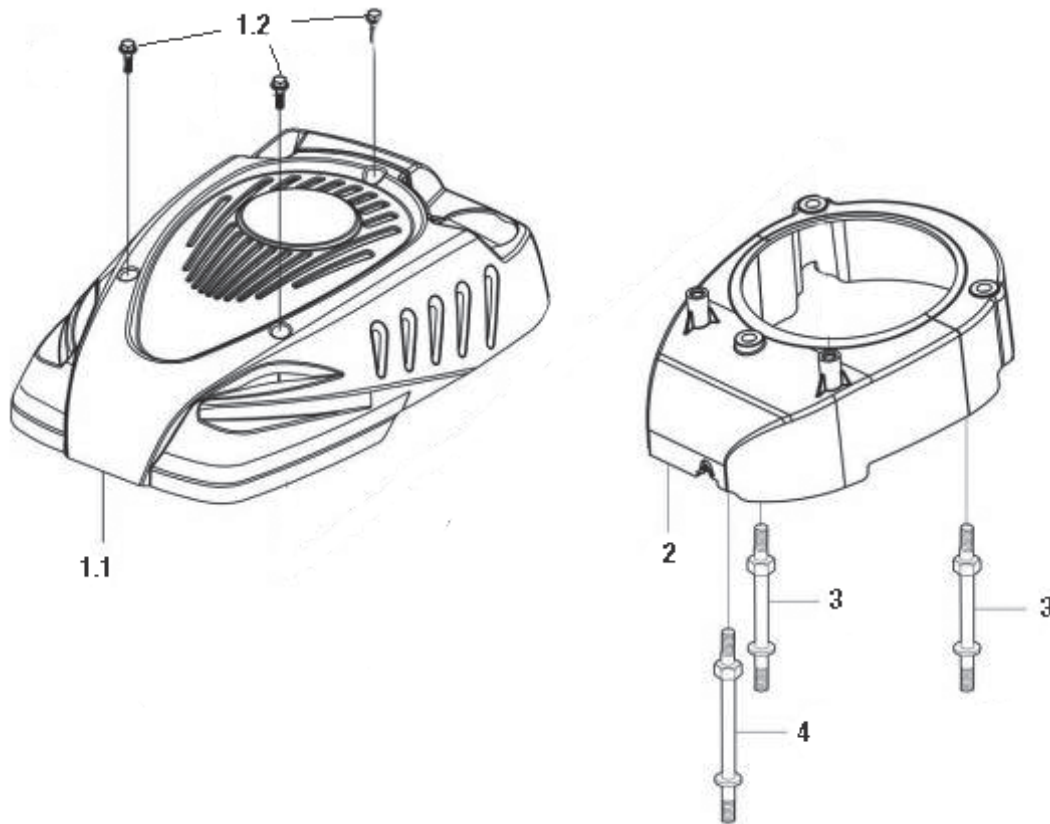

REF. NO.	DESCRIPTION	PART NO.	QTY
1	Kit, Engine Shroud	A201761	1
1.1	Shroud, Engine	Reference Only	1
1.2	Bolt, Housing	A201637	3
2	Shroud, Recoil ASM	A201636	1
3	Stud, Recoil Shroud - 1	A201638	2
4	Stud, Recoil Shroud - 2	A201639	1

NOTE: See page 36 for Decal Kit

Repair Parts

SM2110 ENGINE REPAIR PARTS - RECOIL STARTER

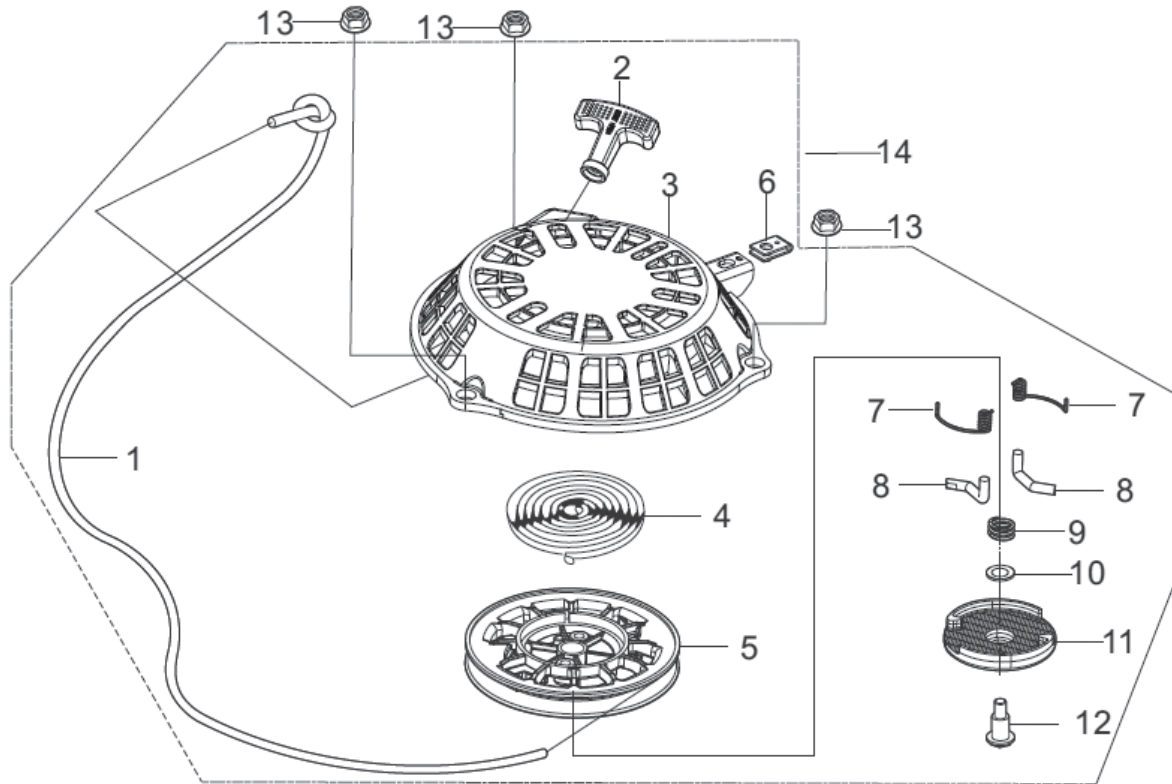

REF. NO.	DESCRIPTION	PART NO.	QTY
1	Rope, Starter	A201640	1
2	Handle, Starter	A201641	1
3	Housing, Starter	A201642	1
4	Spring, Starter	A201643	1
5	Sheave, Starter	A201644	1
6	Clip, Cable Cover	A201645	1
7	Pawl Spring, Starter	A201646	2
8	Pawl, Starter	A201647	2
9	Spring, Retention	A201648	1
10	Spacer	A201649	1
11	Cover, Drive	A201650	1
12	Bolt, Shoulder	A201651	1
13	Nut, Recoil Cover	A201652	3
14	ASM, Recoil Starter	A201653	1

Repair Parts

SM2110 ENGINE REPAIR PARTS - CARBURETOR

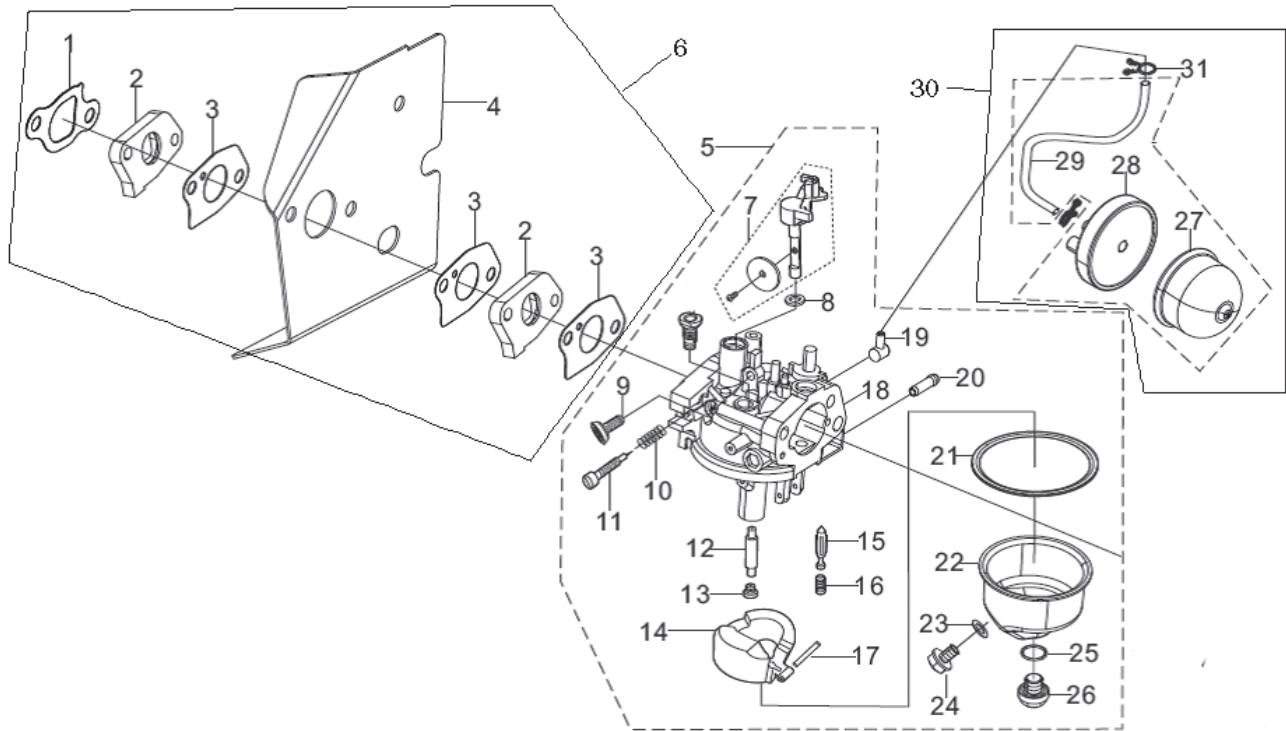

Repair Parts

SM2110 ENGINE REPAIR PARTS - CARBURETOR

REF. NO.	DESCRIPTION	PART NO.	QTY
1	Gasket, Insulator	Reference Only	1
2	Spacer, Gasket	Reference Only	2
3	Gasket, Carburetor	Reference Only	3
4	Heat Shield, Carburetor	Reference Only	1
5	ASM, Carburetor	A201658	1
6	Kit, Carburetor Gasket	A201659	1
7	ASM, Throttle Shaft	Reference Only	1
8	Ring, Seal	Reference Only	1
9	Screw, Air Purge	Reference Only	1
10	Spring, Tension	Reference Only	1
11	Screw, Air Adjustment	Reference Only	1
12	Nozzle, Main	Reference Only	1
13	Nozzle, Jet	Reference Only	1
14	Float	Reference Only	1
15	Valve, Float	Reference Only	1
16	Spring, Float	Reference Only	1
17	Pin, Fulcrum	Reference Only	1
18	Body, Carburetor	Reference Only	1
19	Fitting, Primer Inlet	Reference Only	1
20	Fitting, Fuel Inlet	Reference Only	1
21	Gasket, Float Bowl	Reference Only	1
22	Bowl, Float	Reference Only	1
23	Gasket, Drain Plug	Reference Only	1
24	Plug, Drain	Reference Only	1
25	Gasket, Bowl Retainer	Reference Only	1
26	Retainer, Bowl	Reference Only	1
27	Bulb, Primer	Reference Only	1
28	Body, Primer	Reference Only	1
29	Line, Primer Fuel	Reference Only	1
30	ASM, Primer Bulb	A201683	1
31	Clip, Fuel Line	Reference Only	2

Repair Parts

SM2110 ENGINE REPAIR PARTS - FLYWHEEL/IGNITION

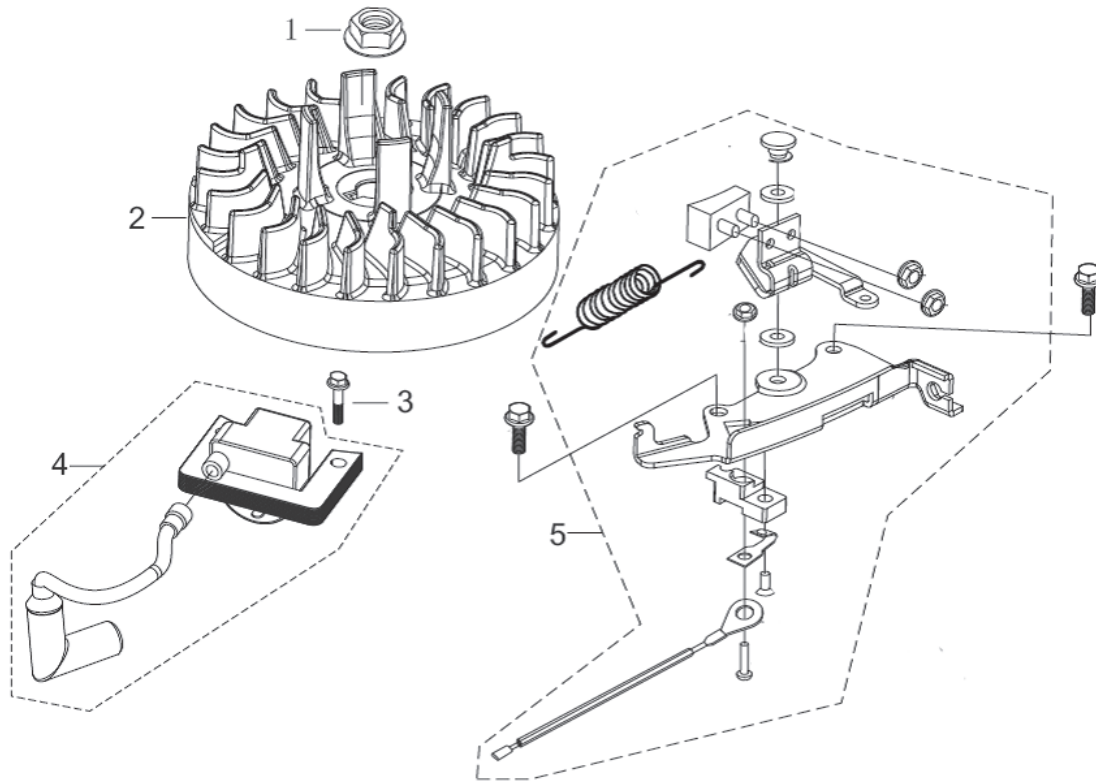

REF. NO.	DESCRIPTION	PART NO.	QTY
1	M14x1.5 Serrated Hex Flange Nut, Zinc, Grade 8	Reference Only	1
2	Flywheel	A202477	1
3	M6x1.0x25 Hex Flange Bolt, Zinc, Grade 8.8	Reference Only	2
4	Module, Ignition	A202478	1
5	ASM, Engine Brake	A202479	1

Repair Parts

SM2110 ENGINE REPAIR PARTS - AIR FILTER

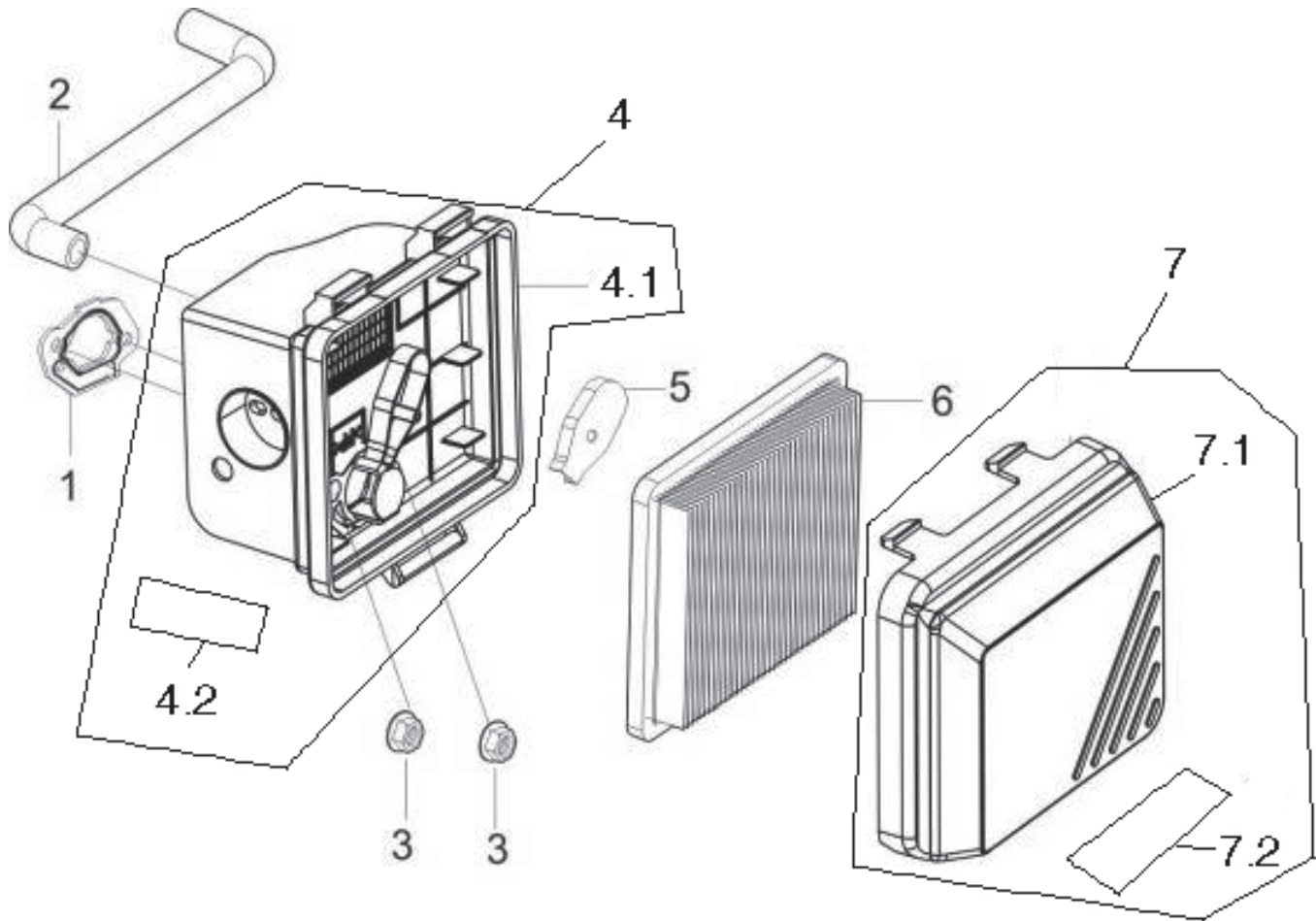

REF. NO.	DESCRIPTION	PART NO.	QTY
1	Gasket, Air Filter	A201696	1
2	Tube, Breather	A201697	1
3	Nut, M6	A201324	2
4	Kit, Air Filter Housing	A201763	1
4.1	Housing, Air Cleaner	Reference Only	1
4.2	Decal, Primer	Reference Only	1
5	Pap, Deflector	A201699	1
6	Element, Filter	A201700	1
7	Kit, Air Filter Cover	A201764	1
7.1	Cover, Air Filter	Reference Only	1
7.2	Decal, Air Filter Maintenance	Reference Only	1

Repair Parts

SM2110 ENGINE REPAIR PARTS - MUFFLER

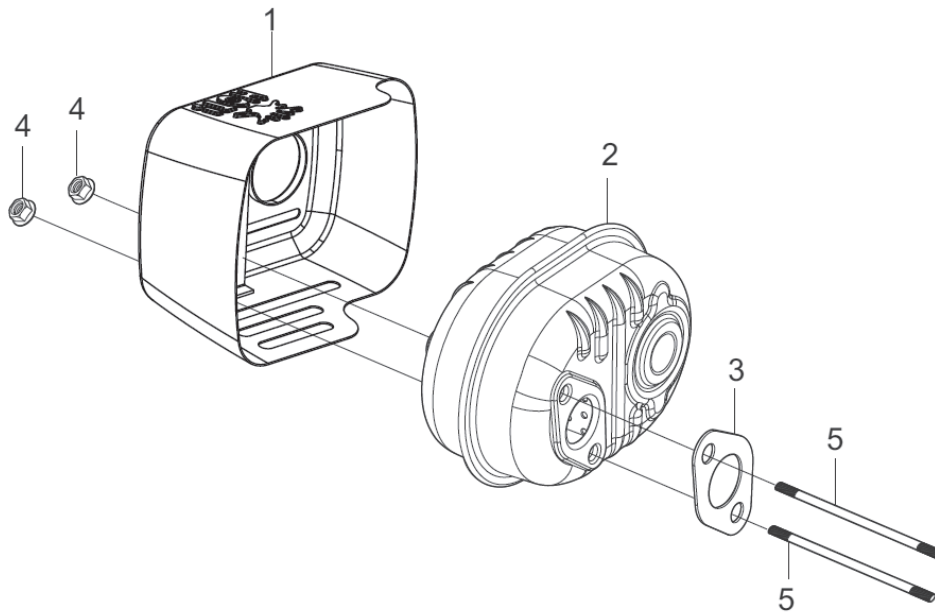

REF. NO.	DESCRIPTION	PART NO.	QTY
1	Shield, Muffler	A201712	1
2	ASM, Muffler	A201713	1
3	Gasket, Muffler	A201714	1
4	Nut, Muffler	A201715	2
5	Stud, Muffler	A201716	2

Repair Parts

SM2110 ENGINE REPAIR PARTS - FUEL TANK

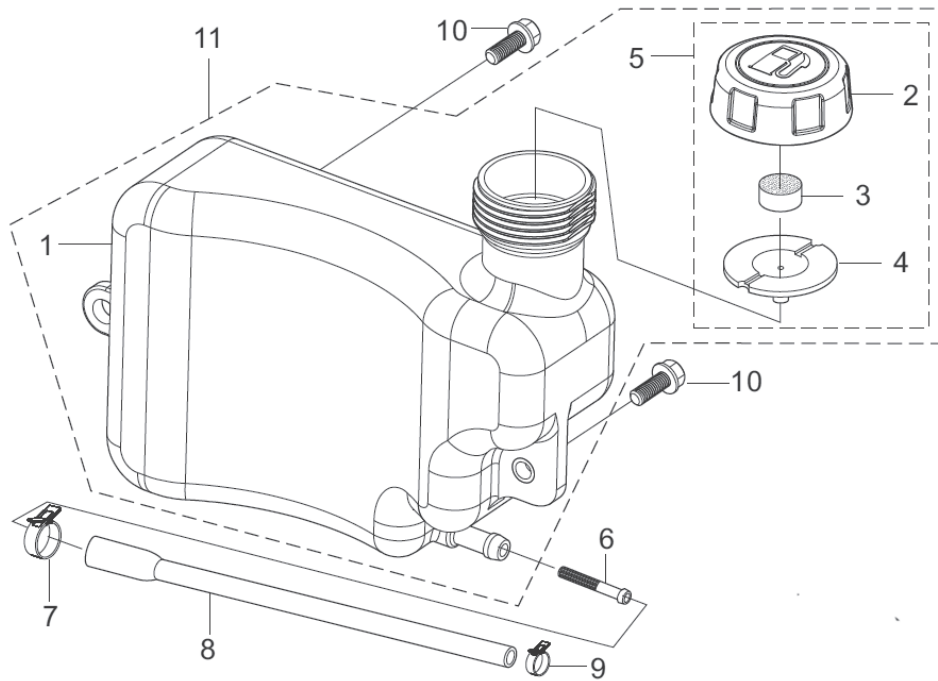

REF. NO.	DESCRIPTION	PART NO.	QTY
1	Tank, Fuel	A203049	1
2	Cap, Fuel	Reference Only	1
3	Filter, Fuel	Reference Only	1
4	Valve, Fuel	Reference Only	1
5	ASM, Fuel Cap	A201721	1
6	Filter, Fuel	A201722	1
7	Clamp, Fuel Line - 1	A201723	1
8	Line, Fuel	A201724	1
9	Clamp, Fuel Line - 2	A201725	1
10	Bolt, Tank Mounting	A201726	2
11	ASM, Fuel Tank	A201727	1

Repair Parts

SM2110 ENGINE REPAIR PARTS - ENGINE LABELS

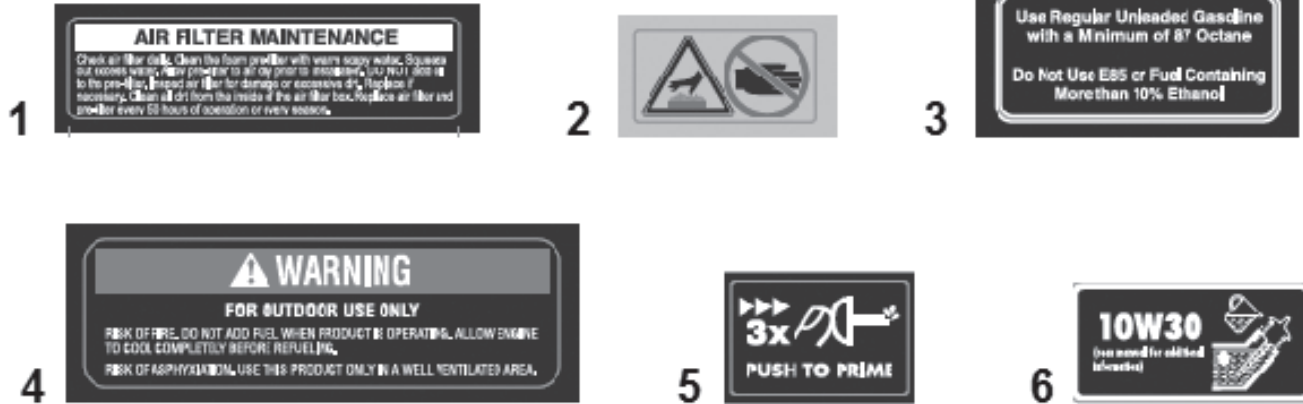

REF. NO.	DESCRIPTION	PART NO.	QTY
1	Decal, Air Filter Maintenance	Reference Only	1
2	Decal, Hot Surface Warning	Reference Only	1
3	Decal, Fuel Usage	Reference Only	1
4	Decal, Outdoor Use Only Warning	A201758	1
5	Decal, Primer	A201759	1
6	Decal, Oil Fill	Reference Only	1
10	Kit, Engine Decal (# 1-9)	A201751	1



If you have a question or problem...

CALL TOLL FREE: 1-800-737-2112